



Phone: 503.257.6604

Fax: 503.253.6564

QUICK CHANGE ORDER FORM

By submitting this form, customer agrees to the current Terms, Conditions, & Policies as stated in the DMI price sheets & web site

SOLD / BILL TO:	SHIP TO:
Name _____	Name _____
Company _____	Company _____
Address _____	Address _____
City _____ State _____ Zip _____	City _____ State _____ Zip _____
DAY PHONE () _____ EVE PHONE () _____	
FAX () _____ Email: _____ @ _____	

<u>Rear Style / Description:</u>	<u>Price:</u>
<input type="checkbox"/> Champ with 4 Rib side bells _____	
<input type="checkbox"/> Champ with 6 Rib side bells _____	
<input type="checkbox"/> Champ with 8 Rib side bells _____	
<input type="checkbox"/> Champ with adaptors (for early tubes) _____	
<input type="checkbox"/> V8 with 12 Rib side bells _____	
<input type="checkbox"/> V8 w/early Ford tubes-cust, plain _____	
<input type="checkbox"/> V8 w/early Ford tubes-cust, polished _____	
<input type="checkbox"/> V8 Center kit, Plain _____	
<input type="checkbox"/> V8 Center kit, Polished _____	
<input type="checkbox"/> Dutchman Supplied Early Tubes _____	
<u>Options:</u>	
<input type="checkbox"/> Change from standard gears to Helicals _____	
<input type="checkbox"/> Extra set of standard change gears _____	
<input type="checkbox"/> Extra set of helical change gears _____	
<input type="checkbox"/> Polished center, bells, & rear cover _____	
<input type="checkbox"/> Polished rear cover only, flat type _____	
<input type="checkbox"/> Polished rear cover only, deep GN type _____	
<input type="checkbox"/> Polished billet rear cover _____	
<input type="checkbox"/> Polished billet yoke _____	
<input type="checkbox"/> Chrome bolt set (center, bells, & cover) _____	
<input type="checkbox"/> Extra Bolt Pattern _____	
<input type="checkbox"/> Access Holes in axle flange _____	

Vehicle: _____

Engine: _____ Tranny: _____ Stall: _____ Trans Brake

Blower Nitrous, HP: _____ Torque: _____ Ratio: _____

Street Strip Roadrace/circle track Offroad

Show only Non performance Mild perf. Hi perf.

<u>Brake Kits & Options:</u>	<u>Price:</u>
<input type="checkbox"/> DMI Drum kit _____	
<input type="checkbox"/> Explorer disc kit _____	
<input type="checkbox"/> Wilwood disc kit _____	
<input type="checkbox"/> Solid rotor <input type="checkbox"/> Vented rotor _____	
<input type="checkbox"/> Plain rotor <input type="checkbox"/> Drilled/slotted/E-coated rotors _____	
<input type="checkbox"/> No E-Brake <input type="checkbox"/> E-Brake _____	
<input type="checkbox"/> Plain calipers <input type="checkbox"/> Polished calipers _____	
<input type="checkbox"/> Baer disc kit _____	
<input type="checkbox"/> Plain rotor <input type="checkbox"/> Drilled/slotted/zinc rotor _____	
<input type="checkbox"/> Plain calipers <input type="checkbox"/> Polished calipers _____	
-If you are supplying your own brake kit, check with us 1st to see if we have the build info for your brake kit. If we don't, you will need to answer the following to the best of your knowledge.	
Manufacturers name and/or model # _____	
Center hole in drum or rotor _____	
Flange OD _____	
Housing end your brake kit was designed for (from chart)	
<input type="checkbox"/> Small Ford, <input type="checkbox"/> Big Ford-Old, <input type="checkbox"/> Big Ford-New	
If other, List style or dimensions _____	
Brake offset from housing flange to axle flange _____	

Office use only: \$ Advance: _____ Rec# _____

Cash Check Money Order Cashiers / Certified

Salesman: _____ Zone: _____ PP# _____

Name: _____

Date: _____

Attn: _____

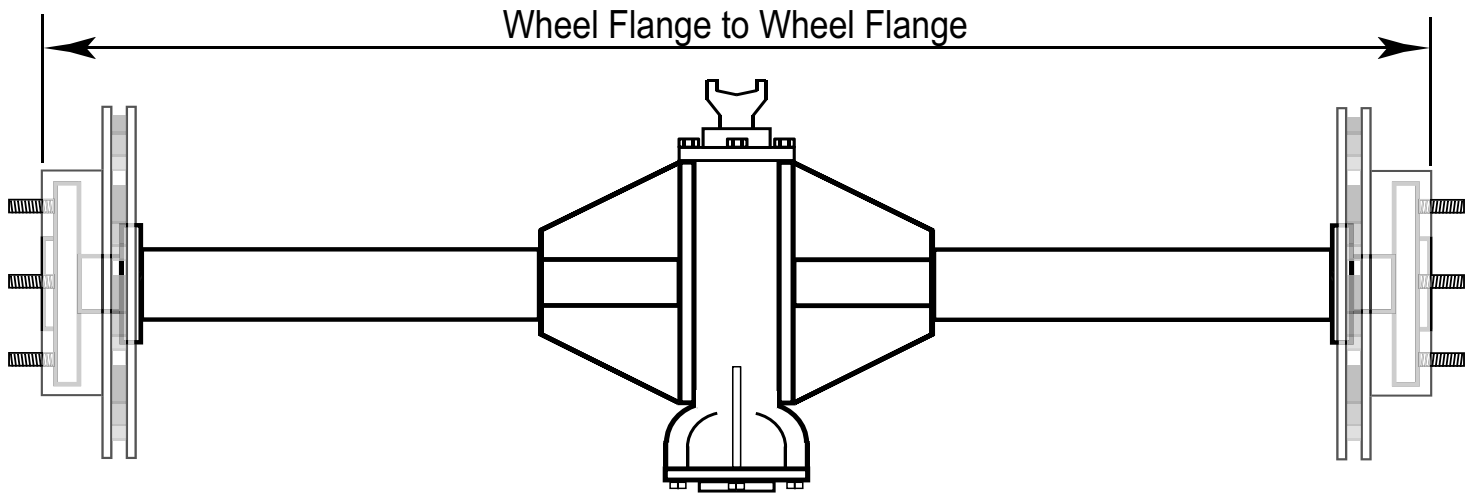

Desired width: _____

-This is to the **wheel** mounting faces & **includes** the thickness of the drums or rotors.

Bolt pattern(s): _____ studs on a _____ diameter bolt circle.

-Optional 2nd pattern: _____ studs on a _____ diameter bolt circle.

Optional Access Holes

Studs: 7/16" 1/2" 5/8" Metric _____ mm x _____ pitch

-Length: Stock Length - press in Extra Long - screw in (1/2" only)
 2" 3"

Gears: (Each unit comes with 1 set of standard change gears)

Final drive ratio choice: _____ Standard, Helicals

Optional 2nd choice: _____ Standard, Helicals

Brackets: If wanting spring perches (leaf spring cars) or brackets welded on, list the details below; Parallel Leaf Transverse Leaf 4 Bar

Customer doing own

Customer supplied

Dutchman supplied

Leaf spring perches

2" 2 1/2" _____

GM Mono leaf _____

GM Multi leaf _____

Brackets installed _____

Brackets loose _____

Brackets slid on tubes - left loose

Cut-N-Call

Bracket center to center _____

Under Top of Housing

Pinion angle _____

Notes _____

Subtotal _____

Shipping _____

Total _____

Customer ok: _____

Bolt Pattern Measuring

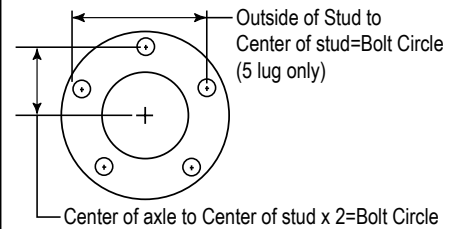

Housing End Identifier

