



Phone: 503.257.6604

Fax: 503.253.6564

"IRS" ORDER FORM

By submitting this form, customer agrees to the current Terms, Conditions, & Policies as stated in the DMI price sheets & web site

SOLD / BILL TO:	SHIP TO:
Name _____	Name _____
Company _____	Company _____
Address _____	Address _____
City _____ State _____ Zip _____	City _____ State _____ Zip _____
DAY PHONE () _____ EVE PHONE () _____	
FAX () _____ Email: _____@_____	

<u>Rear Style / Description:</u>	<u>Price:</u>
<input type="checkbox"/> 9" Ford or 12 Bolt GM "IRS" Rear, No chrome/polish <input type="checkbox"/> 11" Inboard Disc <input type="checkbox"/> 12" Outboard Disc _____	
<input type="checkbox"/> 9" Ford or 12 Bolt GM "IRS" Rear, All chrome/polish <input type="checkbox"/> 11" Inboard Disc <input type="checkbox"/> 12" Outboard Disc _____	
<input type="checkbox"/> Quick Change "IRS" Rear, No chrome/polish <input type="checkbox"/> 11" Inboard Disc <input type="checkbox"/> 12" Outboard Disc _____	
<input type="checkbox"/> Quick Change "IRS" Rear, All chrome/polish <input type="checkbox"/> 11" Inboard Disc <input type="checkbox"/> 12" Outboard Disc _____	
<u>Options:</u>	
<input type="checkbox"/> Brakeline kit _____	
<input type="checkbox"/> Parking Cable brackets (inboard disc only) _____	
<input type="checkbox"/> Spanner wrench & bearing kit (to adjust coilovers) _____	
<input type="checkbox"/> Billet exhaust hanger, natural _____	
<input type="checkbox"/> Billet exhaust hanger, polished _____	
<input type="checkbox"/> Billet exhaust hanger, engrave up to 8 characters _____	
<input type="checkbox"/> 13" Rotor - 6 piston caliper outboard disc option _____	

<u>Optional 3rd member:</u>	<u>Price:</u>
<input type="checkbox"/> 9" Ford: Street _____ <input type="checkbox"/> TruTrac <input type="checkbox"/> TracLoc <input type="checkbox"/> D. Locker	
<input type="checkbox"/> 9" Ford: Street Plus _____ <input type="checkbox"/> TruTrac <input type="checkbox"/> TracLoc <input type="checkbox"/> D. Locker	
<input type="checkbox"/> 9" Ford: Pro Street _____ <input type="checkbox"/> TruTrac <input type="checkbox"/> Trac Loc <input type="checkbox"/> D. Locker	
<input type="checkbox"/> 9" Ford: Aluminum _____ <input type="checkbox"/> Plain <input type="checkbox"/> Polished <input type="checkbox"/> TruTrac <input type="checkbox"/> Trac Loc <input type="checkbox"/> D. Locker	
<input type="checkbox"/> 12 bolt GM : Aluminum _____ <input type="checkbox"/> Plain <input type="checkbox"/> Polished <input type="checkbox"/> TruTrac <input type="checkbox"/> Eaton	
Ratio: _____	
<input type="checkbox"/> 3.00 or 3.25 ratio surcharge (9" only) _____	
<input type="checkbox"/> Double lapped gear surcharge _____	

Vehicle: _____
Engine: _____ Tranny: _____ Stall: _____ <input type="checkbox"/> Trans Brake
<input type="checkbox"/> Blower <input type="checkbox"/> Nitrous, HP: _____ Torque: _____ Ratio: _____
<input type="checkbox"/> Street <input type="checkbox"/> Strip <input type="checkbox"/> Roadrace/circle track <input type="checkbox"/> Offroad
<input type="checkbox"/> Show only <input type="checkbox"/> Non performance <input type="checkbox"/> Mild perf. <input type="checkbox"/> Hi perf.

Office use only: \$ Advance: _____ Rec# _____
<input type="checkbox"/> Cash <input type="checkbox"/> Check <input type="checkbox"/> Money Order <input type="checkbox"/> Cashiers / Certified
Salesman: _____ Zone: _____ PP# _____

Name: _____

Date: _____

Attn: _____

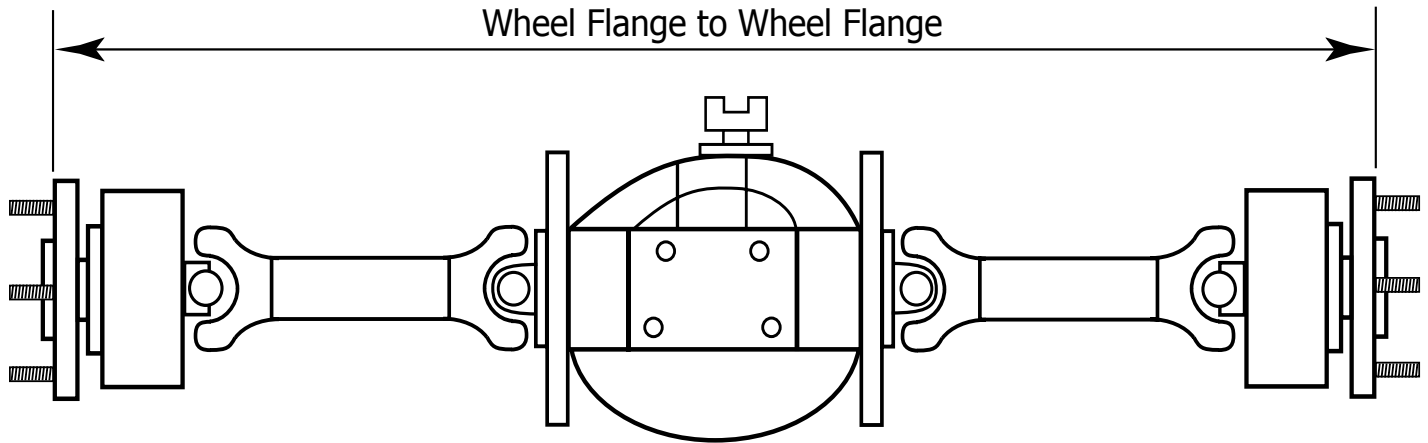

Desired width: _____

-This is to the **wheel** mounting faces & **includes** the thickness of the rotors (if outboard disc option).

Bolt pattern: 5 on 4 1/2" Ford 5 on 4 3/4" Chevy

-Note: Our stub axles come predrilled with 5 on 4 3/4" Chevy bolt pattern. The 5 on 4 1/2" Ford bolt pattern choice will result in a dual pattern in the axle flanges. 1/2"x20 press in style studs come standard.

Frame rail width: _____

-Outside to outside-measured 15" forward of the axle

Frame rail thickness: _____

-Outside to inside

Wheel back space to tire bulge: _____

-Note: If you have great than a 5" back space to tire bulge, spacers will be needed-inquire.

9" Ford only: If a 3rd member (drop out gear set) is desired, fill out the optional 3rd member portion of the order form.

-If you are supplying your own, it will need to be 31 spline if 9" Ford or 30 spline if 12 bolt GM. If your own, what ratio: _____

Quick Change only: Desired final drive ratio: _____

2nd choice ratio if ordering an additional gear: _____

Bolt Pattern Measuring

